

SERIES

AV

VIBRATING FEEDER

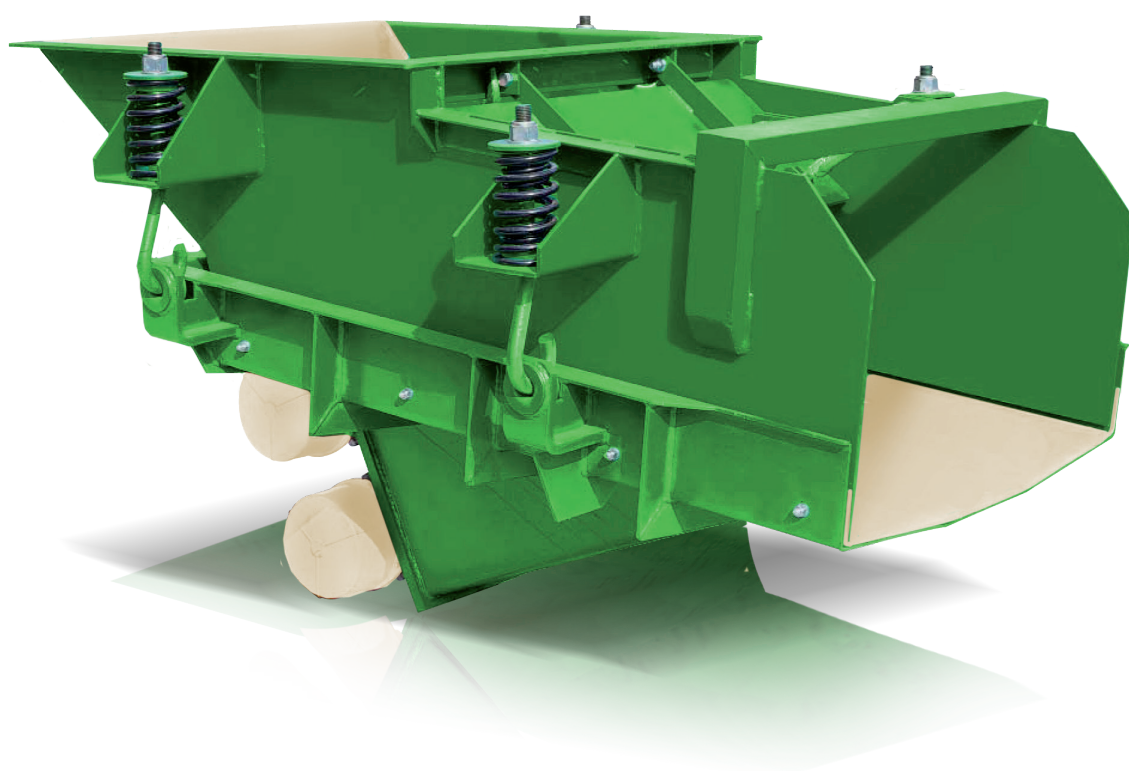

CONSTRUCTION AGGREGATES – MINING – RECYCLING INDUSTRY

Feeder for bulk materials of all kinds

COMEC 

www.comec.it

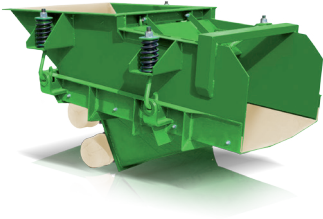

TASK

COMEC vibrating feeders are used for a continuous and controlled feeding of crushers and screens.

SOLUTION

The feeding speed of the material can be perfectly adapted to the individual requirements of our customers due to the adjustable counterweights of the electromechanical vibrators. A set of swinging rods or a blade limit the height of the material layer.

In case dewatering of the feeding material is requested, it is possible to install Polyurethan panels with slots on the vibrating deck.

BENEFIT

COMEC vibrating feeders boast a high tool life and are suitable for any type of bulk material.

Technical data											
Model	Channel size mm	Dimensions in mm						Max. feeding size mm	Output m ³ /h	Power Kw	Weight kg
		L	W	H	A	B	C				
AV 40	440 x 850	910	700	720	400	400	510	0 - 100	30	0,3 + 0,3	150
AV 50	540 x 950	960	820	800	500	500	540	0 - 150	45	0,52 + 0,52	230
AV 60	640 x 1100	1065	930	830	600	600	550	0 - 200	70	0,9 + 0,9	335
AV 70	740 x 1250	1325	1105	1060	700	700	760	0 - 250	80	0,9 + 0,9	425
AV 80	800 x 1500	1525	1240	1180	800	800	815	0 - 300	100	1,0 + 1,0	710
AV 100	1040 x 1500	1425	1470	1180	1000	1000	815	0 - 400	150	1,6 + 1,6	900
AV 120	1240 x 1510	1480	1730	1240	1200	1000	835	0 - 400	150	2,2 + 2,2	1050

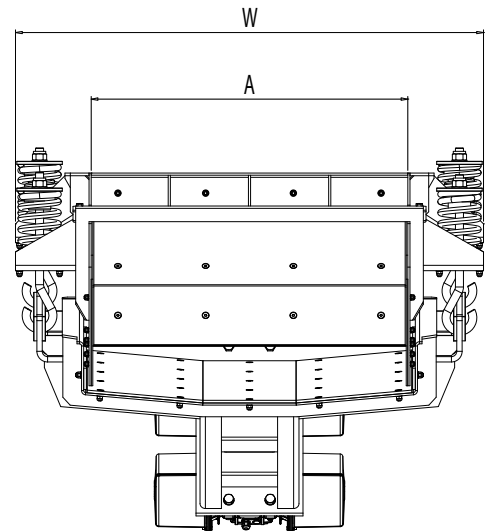
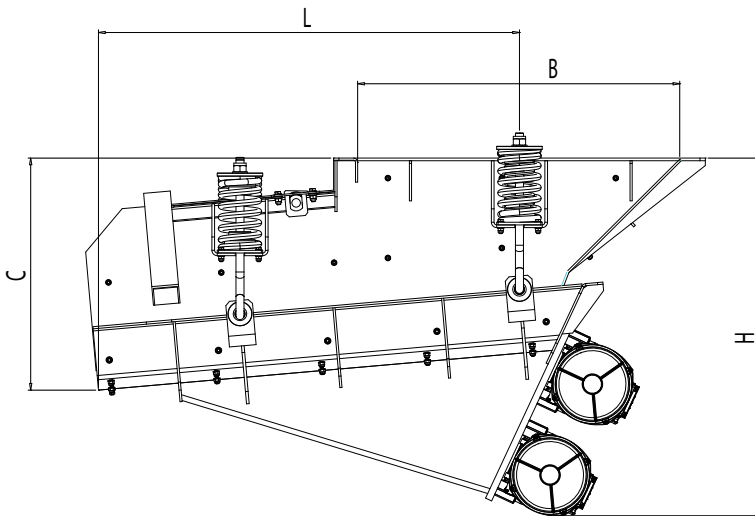

COLOUR

COMEC offers the opportunity to customize both your equipment and production lines with your desired colours, in order to support your own corporate design.

Features and sizes are not binding and Comec-Binder S.r.l. reserves to effect modifications or improvements for commercial and technical reasons at any moment and without notice.