

SERIES

S

SECONDARY JAW CRUSHER



Technical data																			
Type	Dimensions in mm																		
	L	W	H	A	B	C	D	E ¹	E ²	F	G	I	M	N	O	P	Q	R	S
S 800	1950	1865	1465	915	910	810	120	560	560	1010	150	1380	240	890	42	1140	1300	1290	220
S 900	2250	2075	1910	1255	1120	1105	155	800	660	1350	220	1770	300	990	42	1270	1430	1445	240
S 1000	2100	2175	1685	1035	1120	885	140	650	650	1125	200	1580	245	1090	42	1370	1530	1550	240
S 1450	2250	2650	2010	1140	1120	1100	150	700	700	1450	185	1700	290	1530	42	1890	2050	1960	340

Type	Feed opening	Output with a setting at mm								Min. opening	Power requirement	Rotor speed	Flywheels diameter	Weight
		25	30	40	50	60	70	80	90					
	mm	t/h								mm	kW	n/min	mm	kg
S 800	820 x 300	30	40	50	55	65	-	-	-	25	37	320	900	5850
S 900	920 x 500	-	-	55	60	70	80	105	120	40	45 - 55	300	1100	10160
S 1000	1020 x 340	-	50	60	65	75	90	-	-	30	45 - 55	300	1100	8610
S 1450	1450 x 350	-	70	85	95	110	120	-	-	35	90 - 110	300	1120	16300

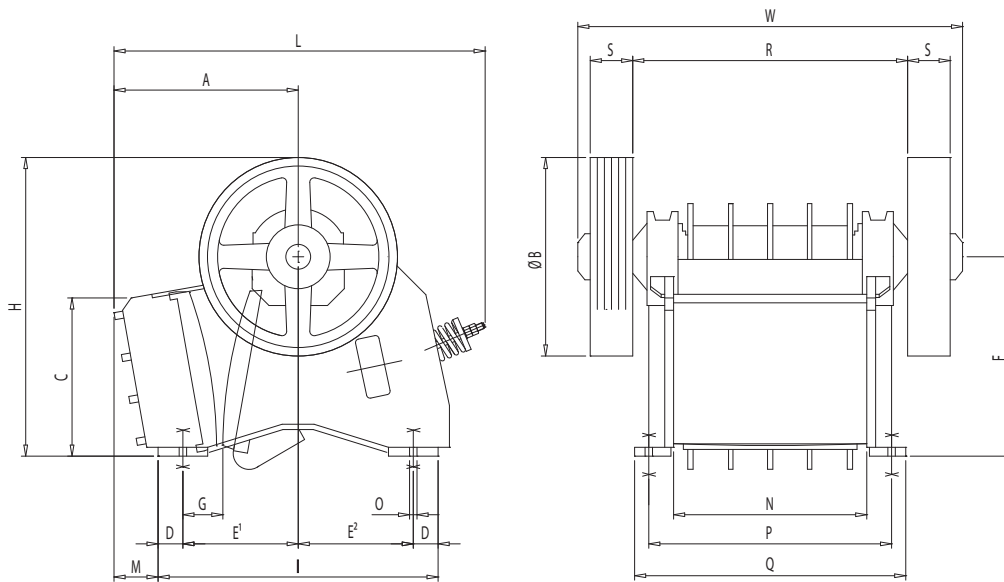

COLOUR

COMEC offers the opportunity to customize both your equipment and production lines with your desired colours, in order to support your own corporate design.

Features and sizes are not binding and Comec-Binder S.r.l. reserves to effect modifications or improvements for commercial and technical reasons at any moment and without notice.